



Determination of the Optimum Aerodynamic Parameters in the Design of Wind Turbine Using COMSOL Multiphysics Software

Yasir A. Abood, Omar A. Abdulrazzaq*, Ghada S. Habib, Zaineb M. Haseeb

Renewable Energy and Environment Research Center/ Corporation of Research and Industrial Development – Iraq

Article information

Article history:

Received: May, 20, 2022

Accepted: July, 17, 2022

Available online: October, 20, 2022

Keywords:

Blade airfoil,
NACA, Glide ratio,
Drag coefficient,
Lift coefficient

*Corresponding Author:

Omar A. Abdulrazzaq
omarsatar2003@gmail.com

DOI:

<https://doi.org/10.53523/ijoirVol9I2ID171>

Abstract

In this research, COMSOL Multiphysics Simulation program was used to calculate the drag coefficients and lift (C_d & C_L) for two-dimensional model and the glide ratio (GR) or so-called C_L/C_d ratio for five airfoils (namely: NACA 2412, NACA 2415, NACA 2418, NACA 4412, and NACA 4415) with two criteria (Reynolds's No. 1×10^5 and 2×10^5). We obtained multiple data from the parameters above by changing the angle of attack (α) each time from 0° to 10° . After that, a comparison was made among all data to obtain the highest glide ratio of all airfoils. Moreover, we obtained the highest stability in angle adjustment during operation. The results drawn as diagrams to understand the relationships. The results give us a hint of which airfoil is preferable to use due to wind velocity whether it is high or low and thus can be related to weather conditions in Iraq. Moreover, we can decide which airfoil is the optimum due to the angle of attack adjustment when the angle reaches its optimum value of glide ratio.

1. Introduction

The design criteria of horizontal axis wind turbines are based on different parameters that will be discussed later in this research. The modern day WPP is very automatic. The components of a turbine are connected to the fields of mechanical, electrical, civil, electronics, and even computer engineering and these all combined fields work together to transfer the wind energy of air into useful electric power. Thus, a team of trained and professional specialists of each field work together to finalize the required design of certain WPP. Most of the prominent turbine manufacturers always concentrate on building bigger WPP, so they can minimize the cost of the wind energy to a substantial value. Figure (1) illustrates the main components of large and fully automated turbine [1].

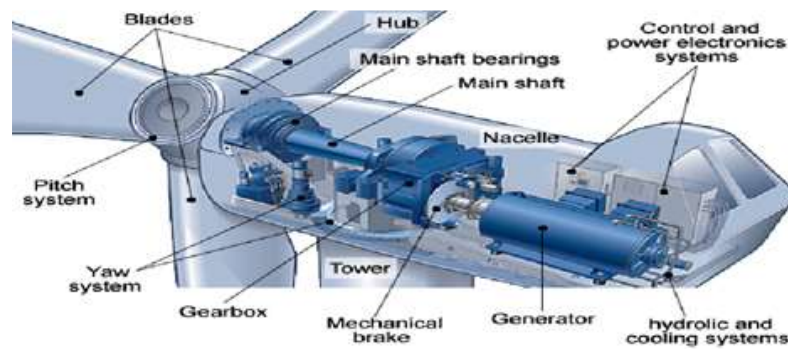

Figure (1). Large wind turbine components.

The best design for a modern WPP is not implemented by technology alone. In reality, the best design is an arrangement between technology & economy. The main target for any engineer is to construct a WPP that produces electrical power for the minimal cost per kilowatt-hour (kWh) of energy [2]. One of the main factors that happened by using new technologies is the need to minimize the life cycle based cost of energy (C_eE) by implementing smart designs to enhance the system workability with high reliability, lower loads, lower funding and operating costs. There is multiple software for designing WPPs such as OPENWIND. The OPENWIND is a wind farm design software for engineers. Moreover, it is an open source and could be downloaded and used free. Figure (2) shows many types of wind power plants (farms) [3].

In actual conditions, the design process is done repeatedly to reach the optimum choice. Every WPP fabricator implements some traditional designed computer software (usually taking into account the customer's point of view) by using computer-based modeling to reach the most preferable criteria. There are major steps that should be considered for a typical WPP the design:

- Analysis of the profitable wind resource data.
- Selecting the application, i.e., onshore, offshore.
- Taking a decision for the power (P) that should produce from WPP.
- Rotor direction, i.e., upwind or downwind.
- Yaw (the direction control mechanism), forced, free, fixed yaw.
- Selection of hub, i.e., rigid, teetering, or hinged.
- Rotor power control, i.e., stall, pitch, or active-stall.
- Rotor velocity, i.e., variable or constant.
- Electrical generator.
- Geared, direct-drive, or hybrid.
- Grid selection.
- Calculating all the expected loads.

Calculating the energy cost for the selected design [4]

In modern countries, the small wind turbines (off-grid) are basic solution to the total wind energy produced worldwide [5, 6]. Small wind industry contributes about 35% of the annual wind energy installed. They can be the solution to provide power in rural areas. They also are key element for the protection of environment.

The development of blades is essential in small wind turbine industry being the element that converts the kinetic energy to electric one. Therefore, the selection of the best parameters for the blades can help in the production of wind energy. The best distribution of chord length and pitch angle in each section of the blade can be gained according to design parameters that includes tip speed ratio and angle of attack. The criteria of cut-in low wind speed

operating has made a significant step through the selection of the best parameters of turbine blades considering that the rotor blades are the key parts in wind energy generating [7, 8, 9].

In this paper, we select from five different airfoils the best parameters of drag and lift coefficients and angle of attack of we calculated the glide ratio so we can show the ability of rotation for each airfoil and the most stable airfoil during rotation by observing the highest value of angle of attack [10, 11].



Figure (2). Different types of wind power plants (horizontal axis wind turbines).

2. Experimental Procedure

Five different airfoils of blades are chosen (NACA 2412, NACA 2415, NACA 2418, NACA 4412, and NACA 4415), each with its own characteristics of maximum thickness, maximum camber, and the position of the maximum camber along the airfoil axis. All these parameters are fed to the program COMSOL and the results of C_L (lift coefficient), C_d (drag coefficient), and the glide ratio (C_L/C_d) are calculated. All the parameters of the airfoil are seen in Figure (3) below:

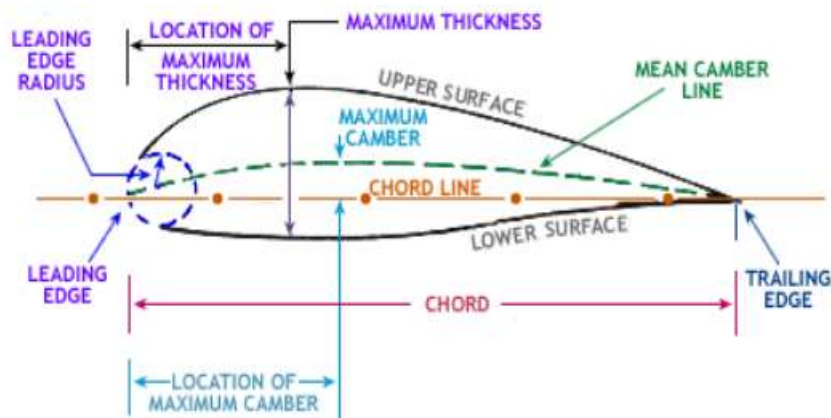

Figure (3). Airfoil of a turbine blade with the main parameters.

The airfoils chosen are all related to small wind turbines criteria and the purpose is to determine which is the best choice between them to use as an optimum wind turbine blade. All of these airfoils are shown in Figure (4).

Moreover, we consider the Reynolds number with two values to take the readings, one with the value of 1×10^5 to simulate the starting value during the starting of rotation (cut-in speed) of the blade, and the other value of 2×10^5 to simulate the criteria of maximum load (maximum rotation speed).

Usually, the small wind turbines operate under Reynolds no. less than 5×10^5 . In reality, and to Reynolds no. range laminar flow (steady state) of air gets splitted streaming on the upper surface of blade and reconnected to surface as turbulent causing laminar separation bubble, thus increasing the drag of the airfoil [12].

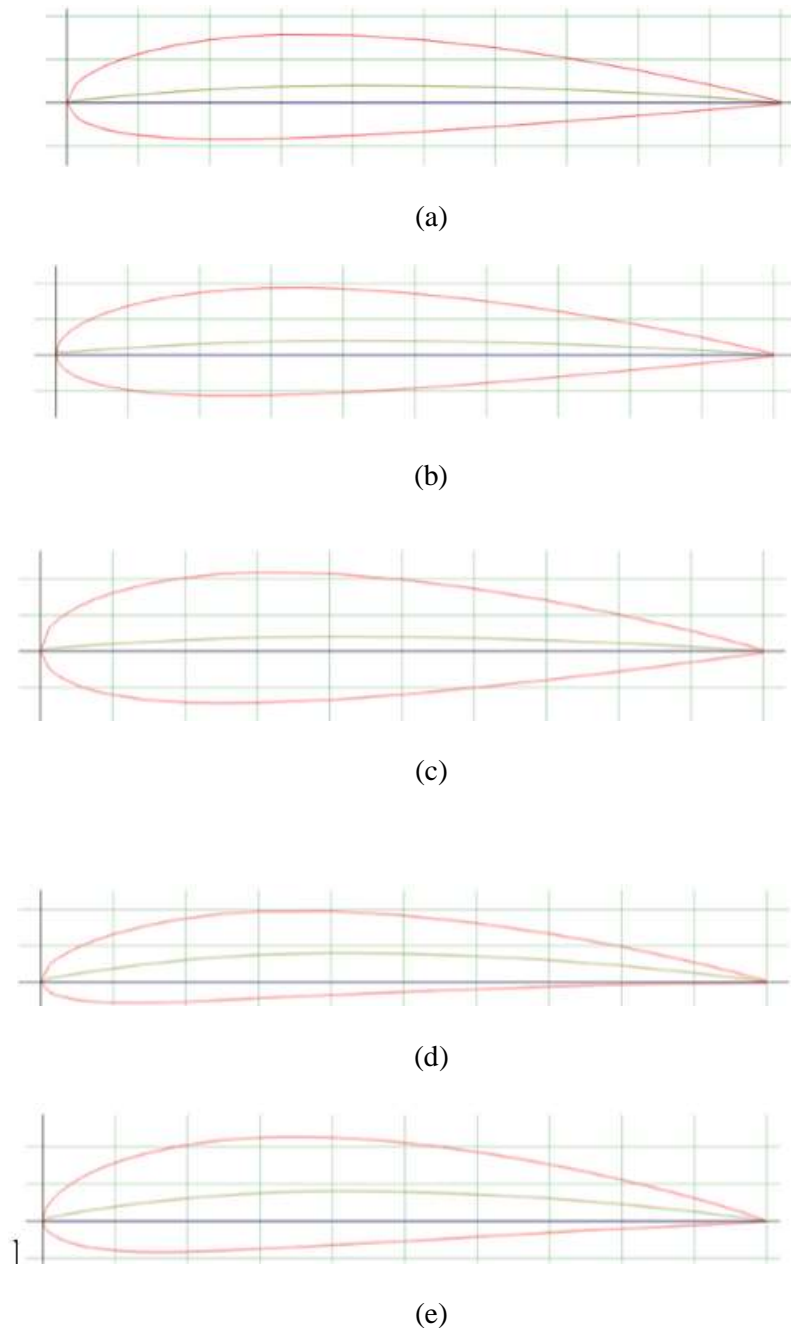

Figure (4). Parabolic shapes of NACA (2412, 2415, 2418, 4412, 4415) as in (a, b, c, d, and e), respectively.

For the angle of attack (α), we chose a wide range of angles starting with 0° to 10° to give us the maximum C_L , C_d and the glide ratio (C_L/C_d). Thus, we could calculate the optimum angle of attack in which we obtain the maximum glide ratio (C_L/C_d). The program gives us the geometry of the airfoil as we can see in Figure (5).

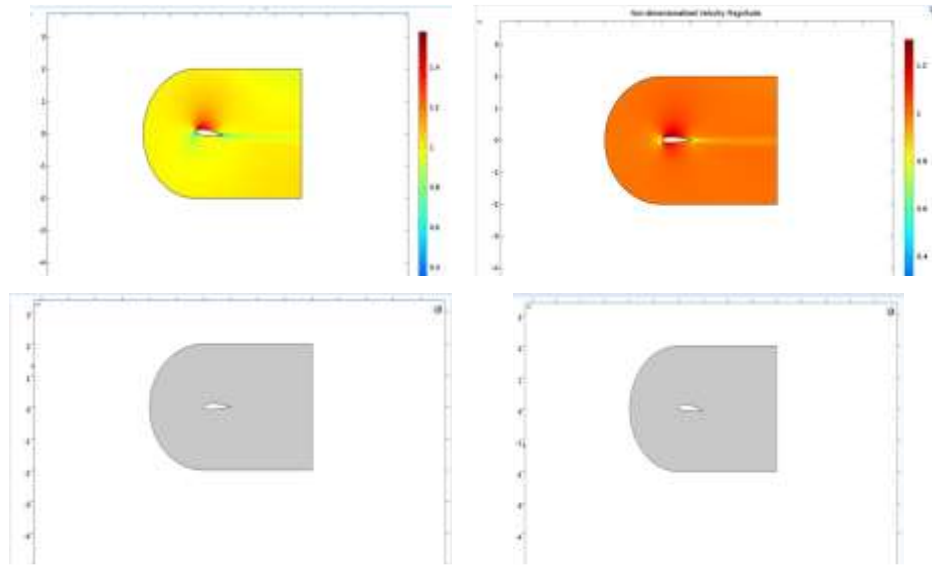

Figure (5). Different types of the geometry of the airfoils containing the changed value of angle of attack (α).

Moreover, the N_{crit} value, which is the measure of the free flow turbulence, is assumed to be the value of nine, which is very commonly used. The velocity of Mach is also assumed to be zero, because the percentage of velocities used (maximum 10 m/s) to Mach No. are very low and can be neglected [13].

3. Results and Discussion

As shown in Figure (6), we see that the maximum glide ratio that reached through the chosen airfoils achieved by the airfoil (NACA 4412) is 31.64 at the low Reynolds No. 1×10^5 which is the first criterion. This gives us the hint to the preferable airfoil that can use during the low readings of wind speed or what we can call it cut-in speed. Moreover, this airfoil is the best to choose during the low winds [14].

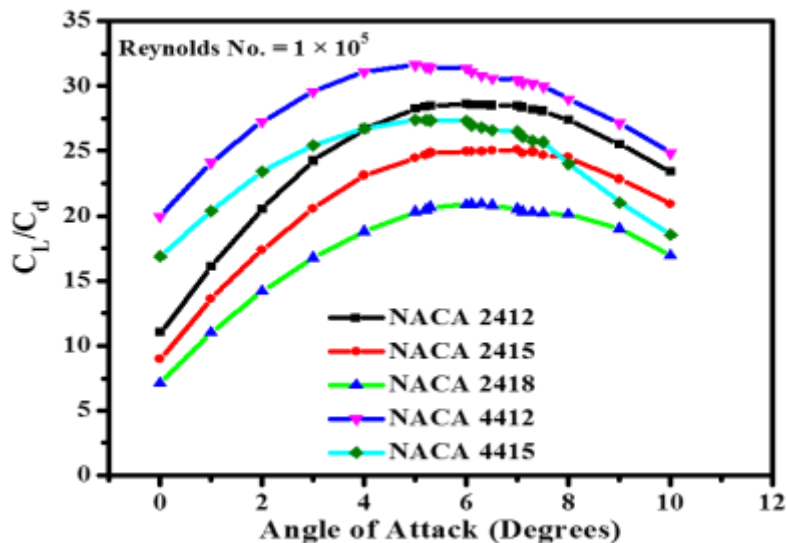

Figure (6). The relation between the glide ratio (C_L/C_d) and angle of attack (α) for the 1st criterion (Reynolds No. 1×10^5).

As shown in Figure (7), we see that the maximum glide ratio for the 2nd criterion when the Reynolds No. is 2×10^5 is reaching 31.94 for both NACA 2412 and NACA 4412. Thus, these airfoils are the most preferable to use during the high wind speed or the optimum wind velocity (peak values of the power generated) during the streaming of the wind or we could call it cutout speed. Moreover, these airfoils are preferable for use in the high velocity winds [15].

Figure (8) demonstrate the difference in angle of attack in the case of maximum glide ratio. This helps us in case to ensure the degree of instability during operation for both criteria chosen. The lowest value of difference exhibits a smooth rotation of the blades during operation. From the figure and for NACA 2412 & NACA 4415 we see no need to adjust the angle and it remains the same, which is the most preferable condition while it oscillates between 0.3° & 1° for the other airfoils [16].

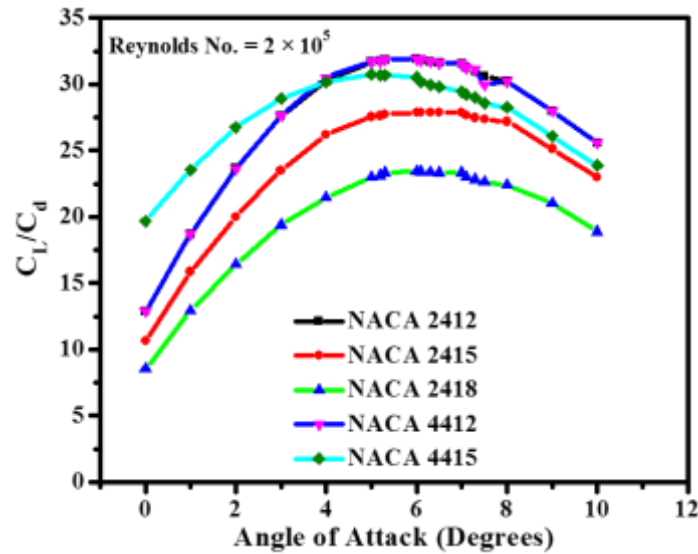

Figure (7). The relation between the glide ratio (C_l/C_d) and angle of attack (α) for the 2nd criterion (Reynolds No. 2×10^5).

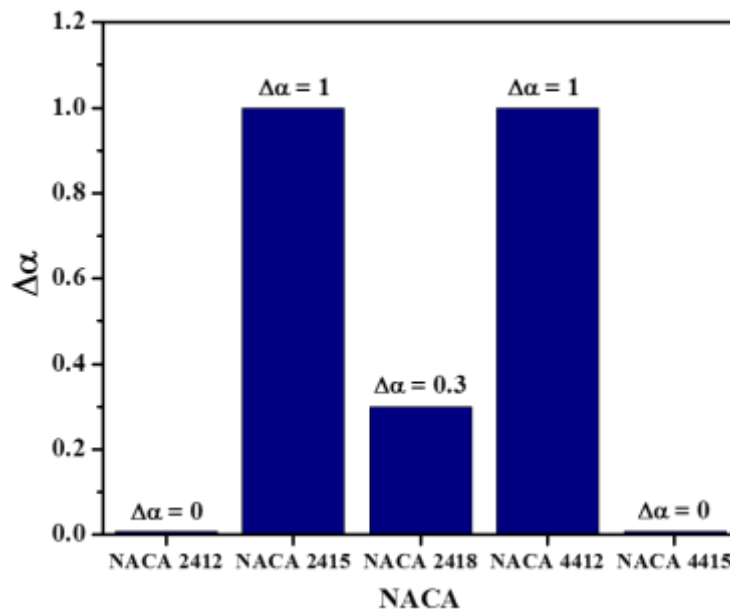

Figure (8). Difference of angle of attack at maximum glide ratio for NACA.

Figure (9) illustrates that with the increase in Reynolds No. there was a reduction in drag coefficient and therefore, an increase in lift-to-drag ratio. Each time we increase the angle, an increase in drag coefficient occurs in parabolic relation for each airfoil [17].

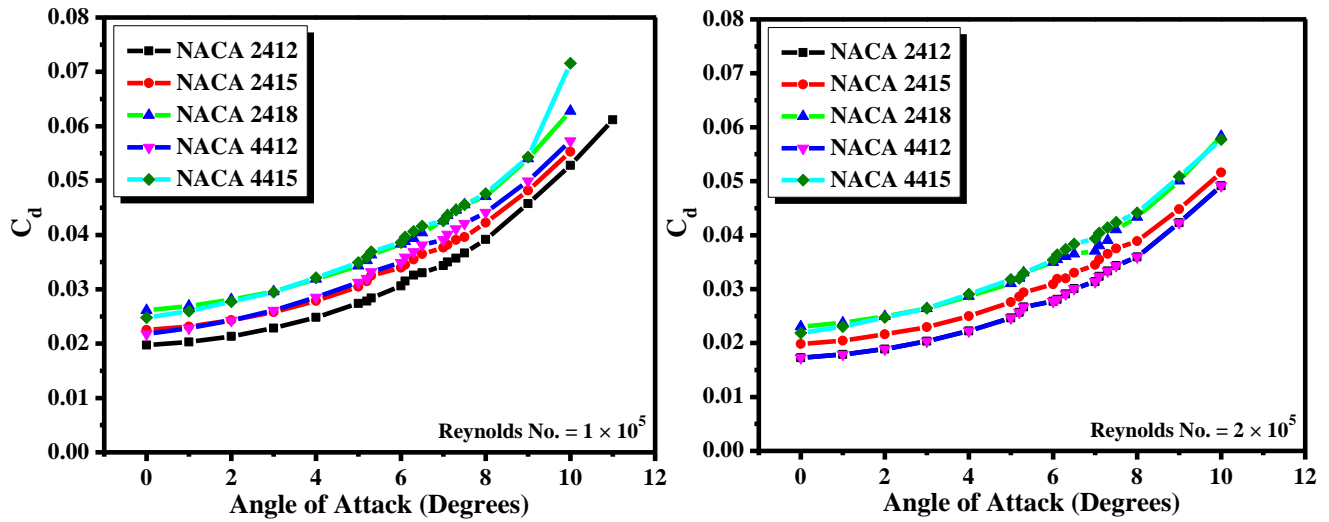

Figure (9). The relation between angle of attack (α) and drag coefficient for both criteria of Reynolds No.

As shown in Figure (10), we see an increase in lift coefficient with the increase of Reynolds No. Moreover, the increase in the angle of attack leads to an increase in lift coefficient in all data [18]. Overall, best simulation results are obtained with airfoil NACA 2412 & NACA 4415.

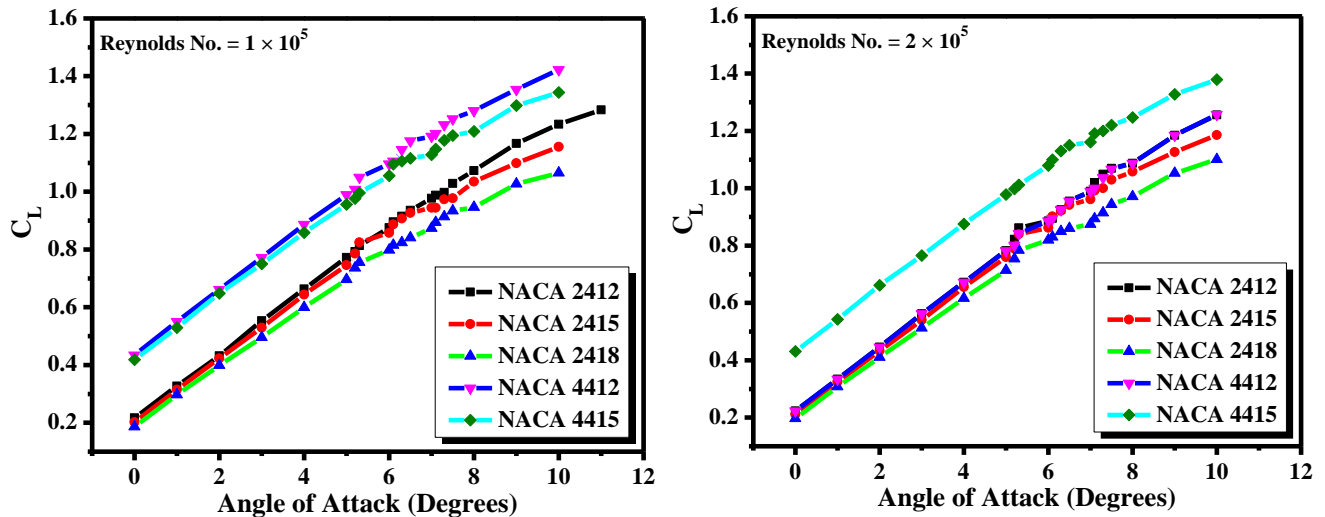

Figure (10). The relation between angle of attack (α) and lift coefficient for both criteria of Reynolds No.

4. Conclusions

The performance of any blade airfoil depends on the values of certain characteristic especially the glide ratio or the ratio between lift coefficients to drag coefficient (C_L/C_d), so when this value is high this means that ability of rotation is increasing which gives the airfoil good behavior during rotation. By comparison between the five airfoils (which all are used in small wind turbines), we can choose the best of them according to the highest readings of GR in both criterion of Reynolds No. 1 & 2×10^5 . In this case, we see that the airfoil NACA 4412 has the best performance in the two conditions. On the other hand, if we look at the stability of rotation during operation (the need to adjust the angle due to change of velocity), we see that the airfoil NACA 2412 & NACA 4415 have the best results.

References

- [1] Brondsted, P., & Nijssen, R. P. (Eds.), "Advances in wind turbine blade design and materials," Elsevier, 2013.
- [2] C. Jung, D. Schindler, "The role of air density in wind energy assessment – A case study from Germany," *Appl. Energy*, vol. 171, pp. 385-392, 2019.
- [3] T. John, "Horizontal Axial Wind Turbine Blade Design Using Ansys Fluent," *J. Multidiscip. Eng. Sci. Stud.*, vol. 2, no. 8, pp. 798–803, 2016.
- [4] T. Burton, *et al.*, Wind Energy Handbook. Chichester, England: John Wiley & Sons, Ltd, 2011.
- [5] Y. Abood, T. A. Ismail, O. A. Abdulrazzaq, and H. S. Hussein, "Evaluation of the Effect of Blades Number on the Performance of Pico Wind Turbines," *Iraqi J. Ind. Res.*, vol. 8, no. 1 SE-Engineering Section, pp. 29–39, Jun. 2021.
- [6] Y. A. Abood, W. E. Kasid, O. Abdulrazzaq, and H. S. Hussein, "Effect of the Blade Pitch on the Performance of Small Wind Turbine Exposed to Wind Stream of Various Angles of Attack," *Iraqi J. Ind. Res.*, vol. 9, no. 1 SE-Engineering Section, pp. 31–38, Jun. 2022.
- [7] H. Al-Qarishey and R. Fletcher, "How variations in downstream computational fluid dynamics turbulence studies can be impacted when employing commonly used initial set-up configuration parameters for airfoils," *ASME International Mechanical Engineering Congress and Exposition, Proceedings (IMECE)*, vol. 6. 11-Nov-2019.
- [8] H. Al-Qarishey and R. Fletcher, "Important educational factors for computational fluid dynamics when teaching new users how to apply commonly employed initial set-up configuration parameters for airfoils," *ASME International Mechanical Engineering Congress and Exposition, Proceedings (IMECE)*, vol. 5. 11-Nov-2019.
- [9] A. Y. Qasim, Y. Al-Douri, and O. Y. Alani, "Wind Energy," in *Renewable Energy*, AIP Publishing LLC, 2022, pp. 6–24.
- [10] H. Al-Qarishey and R. W. Fletcher, "A COMPUTATIONAL FLUID DYNAMICS ANALYSIS of TURBULENCE and WAKES of HORIZONTAL AXIS WIND TURBINES during NON-OPERATIONAL TIME PERIODS," *ASME International Mechanical Engineering Congress and Exposition, Proceedings (IMECE)*, vol. 8. 16-Nov-2020.
- [11] H. Al-Qarishey, R. W. Fletcher, and E. A. Alkareem, "Computational Fluid Dynamics Turbulence and Wake Study of a Utility-Scale Rotating Three-Blade Horizontal Axis Wind Turbine," *ASME International Mechanical Engineering Congress and Exposition, Proceedings (IMECE)*, vol. 8B-2021. 01-Nov-2021.
- [12] N Karthikeyan and T Suthakar, "Computational studies on small wind turbine performance characteristics", XXVII IUPAP Conference on Computational Physics (CCP2015), Journal of Physics: Conference Series, vol. 759, pp. 012087, 2016.
- [13] J. F. Manwell, *et al.*, Wind Energy Explained Theory Design and Application. Chichester, England: John Wiley & Sons, Ltd, 2009.
- [14] Eppler, R. (2012). Airfoil design and data. Springer Science & Business Media.
- [15] M. O. Hansen, Aerodynamics of Wind Turbines. London, England: James & James Ltd, 2000.
- [16] Salgado Fuentes, V., Troya, C., Moreno, G., & Molina, J., "Airfoil Selection Mythology for Small Wind Turbines," *International Journal of Renewable Energy Research*, vol. 6, no. 4, 1410-1415, 2016.
- [17] R. Kumar, *et al.*, "Solidity Study and its Effects on the Performance of A Small Scale Horizontal Axis Wind Turbine," Energy Centre, Maulana Azad National Institute of Technology, 2017.

- [18] E. Hosseini & G. Shahgholian, "Output Power Levelling for DFIG Wind Turbine System Using Intelligent Pitch Angle Control," *Journal for Control, Measurement, Electronics, Computing and Communications*, vol.58, no. 4, pp 363-374, 2018.